

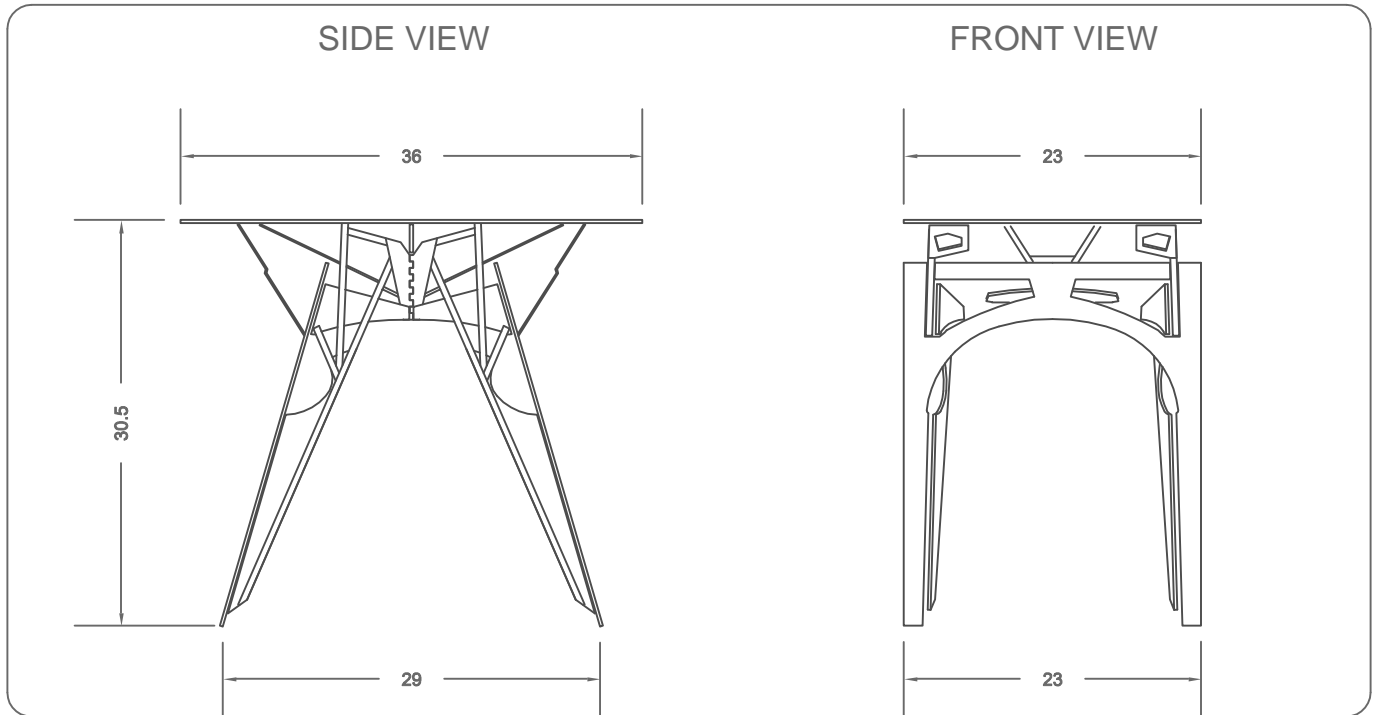

CRICKET TABLE - SPECIFICATIONS

OPEN



CLOSED

FRAME STRUCTURE MATERIAL:	6 MM ALUMINUM COMPOSITE PANEL
HINGES AND PIVOTS:	STAINLESS STEEL
RIVETS:	STAINLESS STEEL
TOP LAMINATE:	ABET LAMINATI
WEIGHT:	20 LBS
TOP WIDTH:	23"
TOP DEPTH:	36"
HEIGHT:	30.5"
BASE WIDTH:	23"
BASE DEPTH:	29"
WIDTH (FOLDED):	0.75"

